



## Code Compliance Research Report

## CCRR-0113

Subject to Renewal: 09/26/2012  
Visit [www.ati-es.com](http://www.ati-es.com) for current status

Issued: 09/26/2011  
Page 1 of 6

**Sunoptics Prismatic Skylights, Inc.**  
**6201 27<sup>th</sup> Street**  
**Sacramento, CA 95822**  
**(916) 395-4700**

[www.sunoptics.com](http://www.sunoptics.com)

### 1. Subject

*Sunoptics Prismatic Skylights*  
*Baylight™ Prismatic Skylights*

*Sunoptics Prismatic Skylights* are also labeled and sold as *Baylight™ Prismatic Skylights* as an approved third party private label. References to *Sunoptics* and *Baylight™* are interchangeable throughout this report.

Model(s):

*5060 Sunoptics “Double Hip” (Frame Model #800MD), Fixed Assembly*

*50100 Sunoptics “Signature” (Frame Model # 800MD) Fixed Assembly*

### 2. Research Scope

#### 2.1 Building Codes:

- 2009 International Building Code (IBC)
- 2009 International Residential Code (IRC)

#### 2.2 Properties:

- Structural Performance
- Durability
- Burning

### 3. Description

3.1 General – The Sunoptics Prismatic Skylight models noted in Section 1 are fixed unit skylights with general dimensions as shown in Table 1. Each of these models utilize framing members of identical cross section and identical mounting configuration. Only the perimeter lengths vary to make frames of the required dimensions. The numbers of fasteners vary with skylight size and are shown in Table 1.

The single glazed *Signature* and *Double Hip* skylight forms utilize prismatic lenses of Class CC2 extruded acrylic plastic. Glazing materials and their associated thicknesses are as outlined in Table 1. An aluminum curb frame is mounted

to a wood curbing, using No. 12 X 1-½ inch long hex washer head screws to form the base of the skylight assembly. Airseal foam neoprene gasket tape is utilized between the horizontal mating surfaces of the wood curb and the aluminum curb frame. The plastic glazing is mounted on top of the curb frame using GE SCS1000 Silicone sealant. An aluminum thermal break frame is assembled over the glazing and engages the lower aluminum curb frame in a “snap-on” arrangement. No. 8 x ½ inch wafer modified truss head screws are installed to secure the aluminum pieces. Additional details of the skylight assemblies are shown in Figures 1 and 2. Further details of materials utilized in the assembly are as follows;

**3.2 Glazing Materials:** Single glazed prismatic and smooth thermoforming raw acrylic material is manufactured by Arkema and is recognized in ICC-ES Evaluation Report, ESR-1653.

3.2.1 The 50100 “Signature” models utilize a glazing manufactured from Arkema DR101 Acrylic extruded to a thickness of 0.160 inch. See Table 1.

3.2.2 The 5060 “Double Hip” models utilize a glazing manufactured from Arkema MI7 Acrylic extruded to a thickness of 0.230 inch. See Table 1.

**3.3 Aluminum Components:** The curb frame and the thermal break curb are manufactured from extruded 6063-T6 tempered aluminum.

#### 3.4 Gasketing and Sealants:

3.4.1 Airseal foam neoprene gasket tape is utilized between the horizontal mating surfaces of the wood curb and the aluminum curb frame

3.4.2 Sealing between the glazing domes and the aluminum framing is accomplished with GE SCS1000 Silicone glazing sealant.

**3.5 Fasteners:** Fasteners utilized in the skylight assemblies are manufactured by PrimeSource Building Products and are recognized in ICC-ES Evaluation Report, ESR-1408. See Table 1 for descriptions and quantities.

3.5.1 The aluminum curb frame is fastened to the wood curbing utilizing zinc plated No. 12 X 1 ½ inch self drilling hex washer head screws.

3.5.2 The aluminum thermal break curb is fastened to the curb frame using zinc plated No. 8 X 1/2 inch wafer modified truss head screws.

#### **4. Performance Characteristics**

4.1 For the models listed in Section 1, the maximum allowable positive and negative (wind uplift) loads are as indicated in Table 2.

4.2 Each of the models listed in Section 1, were tested and determined to be acceptable to the uniform load, water resistance and air infiltration acceptance criteria described in Part A of the ICC-ES AC16, Acceptance Criteria for Plastic Glazed Skylights, approved April 2011.

#### **5. Installation**

Skylights shall be installed in accordance with the manufacturer's installation instructions (dated 2011, Revision 02) and the details and drawings included in this report. Where differences occur between this report and the manufacturer's installation instructions, this report shall govern.

5.1 Skylights shall be installed in accordance with IBC Sections 2405 and 2610 and IRC Section R308.6.

5.2 Skylights shall be mounted on a wood curb that raises the plastic glazing at least 4 inches above the plane of the roof.

5.3 Outside curb dimensions are indicated in Table 1. The design, attachment, flashing and placement of the wood curb to the roof deck is outside the scope of this report.

5.4 Skylights shall be attached to the curb utilizing fasteners described in this report. The fastener manufacturer, type, quantity and location are outlined in Table 1.

#### **6. Supporting Evidence**

6.1 Manufacturer's drawings and installation instructions (dated 2011, Revision 02).

6.2 Reports of testing demonstrating compliance with ICC-ES AC16, Acceptance Criteria for Plastic Glazed Skylights, approved April 2011.

6.3 Quality control manual in accordance with ICC-ES AC10, Acceptance Criteria for Quality Control Manuals, approved June 2011.

#### **7. Conditions of Use**

The *Sunoptics Prismatic Skylights* identified in this report are deemed to comply with the referenced building codes subject to the following conditions.

7.1 Design loads do not exceed loads indicated in Table 2 of this report.

7.2 Wood curbs must have a minimum specific gravity of 0.43 and a minimum thickness of 1-½ inch and sufficient height to mount the plastic glazing higher than 4 inches above the plane of the roof.

7.3 Fasteners are installed in accordance with manufacturer instructions and this report.

7.4 The status of this report is contingent on the validity of the ICC-ES reports identified herein. The revocation or expiration of any included ICC-ES reports will invalidate this report.

7.5 Where required by the building official, engineering calculations and details shall be provided. The calculations shall verify that the anchorage complies with the building code for the type of framing and condition of the supporting construction.

7.6 The *Sunoptics Prismatic Skylights*, and Baylight™ Prismatic Skylights, are manufactured by Sunoptics Prismatic Skylights, Inc., Sacramento, CA, in accordance with the manufacturer's approved quality control system with inspections by Architectural Testing, Inc. (AA-676).

#### **8. Identification**

*Sunoptics Prismatic Skylights* produced in accordance with this report shall be identified with labeling that includes the following information:

8.1 The manufacturers (or approved third party noted in this report) name and/or logo

8.2 The manufacturer's address (or approved third party noted in this report)

8.3 The mark of the independent inspection agency, Architectural Testing, Inc. (AA-676)

8.4 The ATI Code Compliance Research Report Number (CCRR-0113)

8.5 The plastic dome classification (CC2) and thickness of plastic glazing material prior to thermoforming

8.6 Safety labeling indicating "Risk of Fall" that complies with Class 1, ANSI Standard Z35.1 specifications for accident prevention signs.

### **9. Code Compliance Research Report Use**

9.1 Approval of building products and/or materials can only be granted by a building official having legal authority in the specific jurisdiction where approval is sought.

9.2 Code Compliance Research Reports shall not be used in any manner that implies an endorsement of the product or manufacturer by ATI.

9.3 Reference to the Architectural Testing internet web site at [www.ati-es.com](http://www.ati-es.com) is recommended to ascertain the current version and status of this report.

**Table 1 - Skylight Models and General Description**

Skylight Description					Glazing Description		Curb and Fastener Description			
Model Series <sup>(1)</sup>	Frame Model	Size	Skylight Shape	Dome Rise (in)	Glazing Material	Glazing Thickness (in)	Nominal Outside Curb Dims.	Fastener Description (Curb Frame to Curb)	Number of Fasteners	Fastener Spacing (Measured on outside of aluminum curb frame)
Sunoptics Double Hip	800MD	5060 5ftx6ft	Double Hip	11-3/4	Arkema MI7 Acrylic	0.230	63" X 75"	Zinc plated No. 12 X 1 ½ inch self drilling hex washer head screws*	16	7 3/8" from each corner and equally spaced between for a total of 3 fasteners per 5 ft side and 5 fasteners per 6 ft side (16 fasteners total)
Sunoptics Signature	800MD	50100 5ftx10ft	Signature	16	Arkema DR101 Acrylic	0.160	63"X 123"	Zinc plated No. 12 X 1 ½ inch self drilling hex washer head screws*	26	8" from each corner and equally spaced between for a total of 3 fasteners per 5 ft side and 10 fasteners per 10 ft side ( 26 fasteners total)

\* Fasteners Manufactured by Primesource Building Products Ref. ICC-ES Report # ESR-1408

<sup>(1)</sup>Sunoptics Prismatic Skylights are also sold as Baylight™ Prismatic Skylights as an approved third party private label

**Table 2 - Skylight Models and Allowable Loadings**

Model Series <sup>(1)</sup>	Frame Model	Size	Skylight Shape	Allowable Live Load (psf)	Allowable Wind Uplift (psf)
Sunoptics Double Hip	800MD	5060	Double Hip	20	20
Sunoptics Signature	800MD	50100	Signature	20	20

<sup>(1)</sup>Sunoptics Prismatic Skylights are also sold as Baylight™ Prismatic Skylights as an approved third party private label

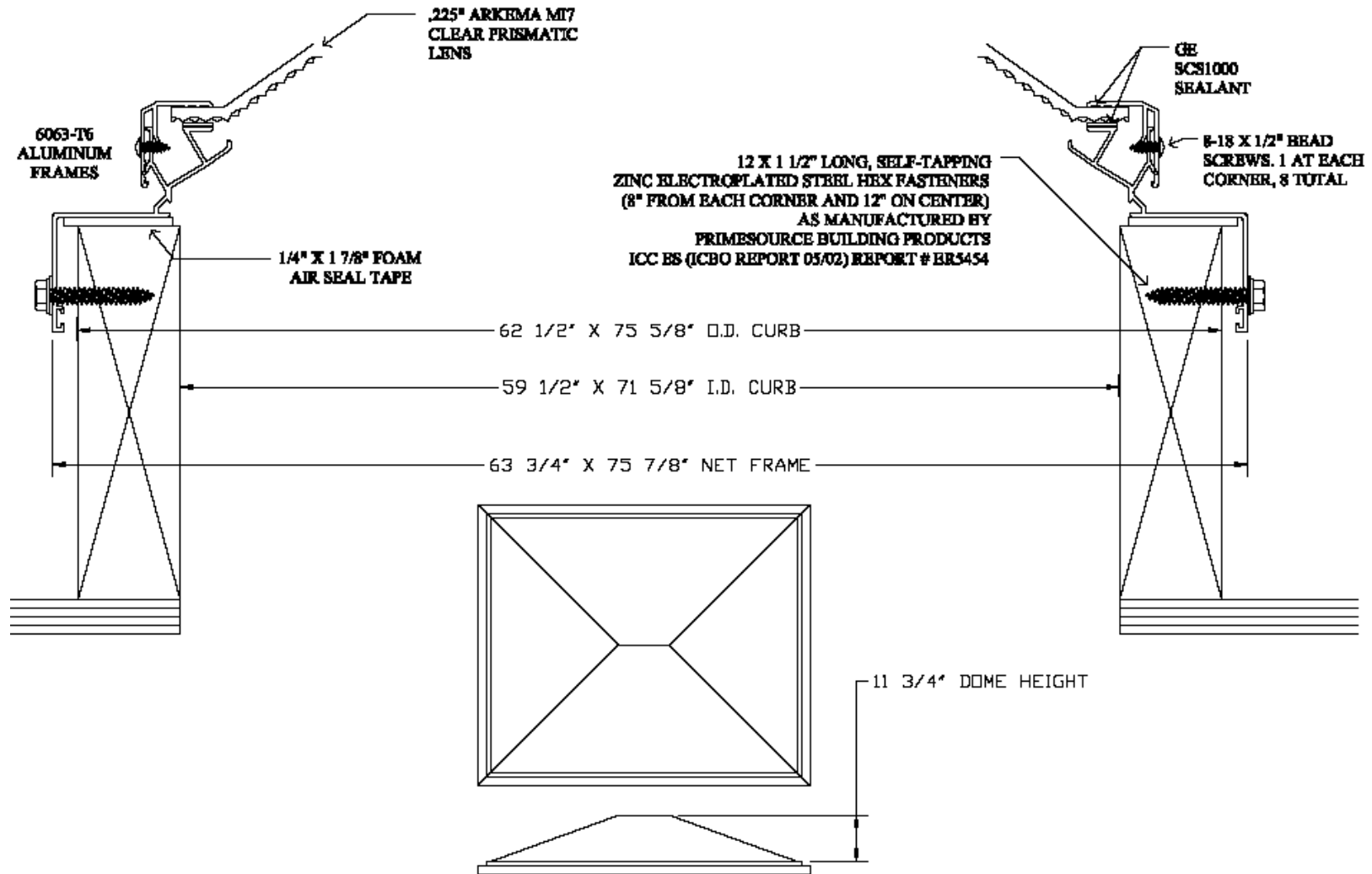
**Figure 1 – 5060 Model 800MD Double Hip**

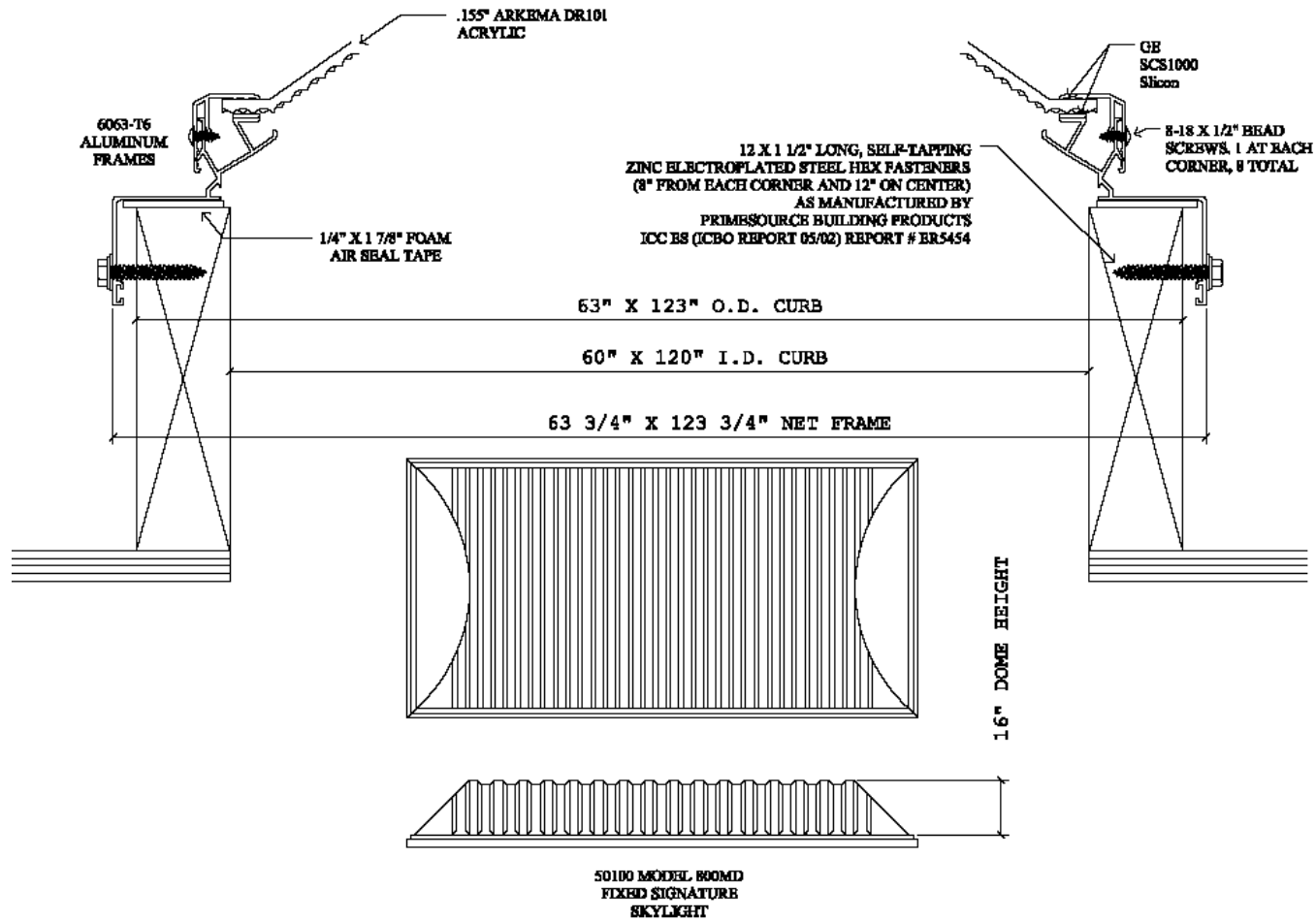
**Figure 2 – 50100 Signature, 800MD**