

Signature Series Dome

Fixed Industrial Skylight

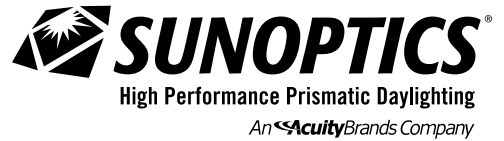

Frame Model 800MD

KEY FEATURES

AVAILABLE CERTIFICATIONS

FM Approval # 4431
 HVHZ Approved
 CE Certified

PRODUCT PROFILE

Details Not To Scale

DGZ LENSCLWH Option Shown

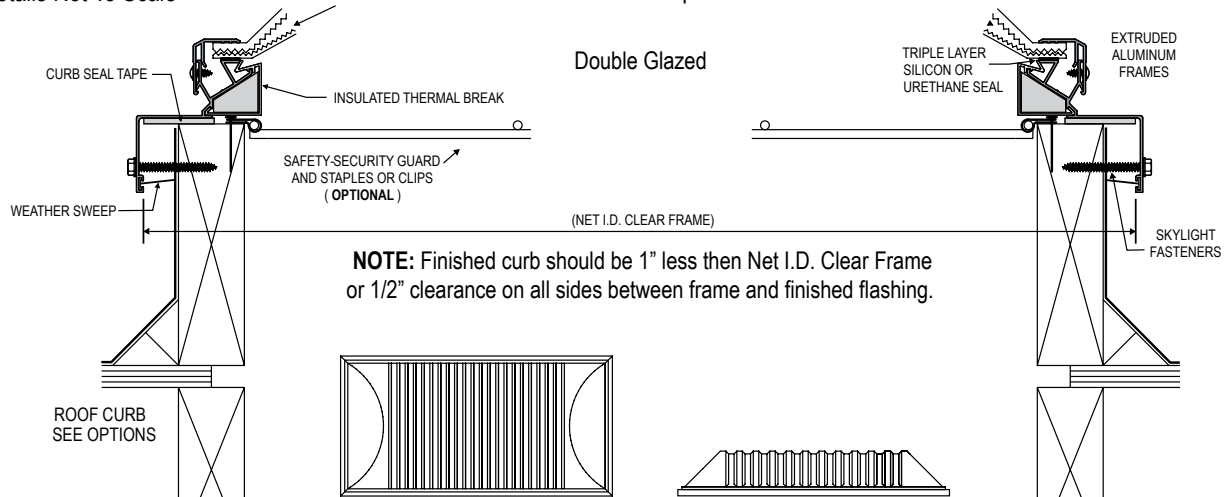

SPECIFICATIONS

Skylights shall be Sunoptics model 800MD (curb mounted) as manufactured by Sunoptics Skylights, 6201 27th Street, Sacramento Ca. 95822 916/395-4700

Skylights shall be glazed ready for installation.

Skylight frames shall be fabricated from 6063 T6 aluminum, finish to be natural mill. Frames shall have integral condensation and weepage gutters which drain interior moisture to the outside. Corners shall be mitered and welded. The acrylic glazing shall be separated from the skylight frame with a Silicon Seal.

Skylights shall be glazed using 50% or 100%, Impact Modified CC2 Acrylic and/or CC1 rated, polycarbonate in a Signature Series Dome configuration.

FM Approved Skylights shall be Double glazed using CLEAR ARMOR® Clear Polycarbonate Prismatic over CLEAR ARMOR® High White Polycarbonate Prismatic lens, CC1/Class A Rated, FM Approved, 5 year hail proof warranted.

FM Approved Skylights shall be tested and approved under Factory Mutual #4431 testing method for fixed skylights. Class A / CC1 flame rating. Standard Size units up to 5080 are tested and certified to AAMA/WDMA/CSA101/I.S.2/A440-05 to comply with section 2405.5 of the International Building Code.

Note: Multi-glazed units default to include Insulated Thermal Break (ITBR), CTape, Weather Sweep (WSW) and screws. Single-glazed units default to not included any of these options.

Testing was performed on HVHZ skylights per Florida Building Code, Test Protocols for High Velocity Hurricane Zone (HVHZ), Protocols TAS 201-94, TAS 202-94 and TAS 203-94. The samples tested met the performance requirements set forth in the protocols for a ±60.0 psf Design Pressure rating.

(Optional) Safety Security Screen fabricated from a 4" X 4" wire mesh galvanized cold rolled steel. The safety screen shall be tested to withstand the impact of a 240 pound weight, one foot in diameter, dropped from a height of 3 feet and support a concentrated load of 600 pounds after the impact. Install using Staples or Clips provided at 12" O.C. between cross members.

Type	SHGC	U-Value	VLT
CT1 - Acrylic	.42	.46	.63
CT2 - Acrylic	.39	.37	.58
CT3 - Acrylic	.35	.28	.53
CT1 - Polycarbonate	.42	.46	.59
CT2 - Polycarbonate	.39	.37	.54
CT3 - Polycarbonate	.35	.28	.50

ORDERING LOGIC

Signature Series Dome



Fixture	ID Frame Dimensions	Glazing	Lens Material	Lens Colors
SIG Signature Series	2020 27-1/4" x 27-1/4" 2040 27-1/4" x 51-1/4" 2080 27-1/4" x 99-1/4" 20100 27-1/4" x 123-1/4" 3030 39-1/4" x 39-1/4" 3050 39-1/4" x 63-1/4" 3060 39-1/4" x 75-1/4" 3080 39-1/4" x 99-1/4" 30100 39-1/4" x 123-1/4" 4040 51-1/4" x 51-1/4" 4050 51-1/4" x 63-1/4" 4060 51-1/4" x 75-1/4" 4070 51-1/4" x 87-1/4" 4080 52-1/4" x 100-1/4" 40100 52-1/4" x 123-1/4" 5050 63-1/4" x 63-1/4" 5060 63-5/8" x 75-5/8" 5558 67-3/4" x 70-3/4" 5070 63-1/4" x 87-1/4" 5080 63-1/4" x 99-5/8" 50100 63-1/4" x 123-1/4"	SGZ Single Glaze DGZ Double Glaze TGZ Triple Glaze	CC1HVHZ Polycarbonate CC1 Polycarbonate CC2CL1 Acrylic Class 1 CC2CL3 Acrylic Class 3	LENSWH White (Single Glaze Default) ¹ LENSCL Clear ¹ LENSWHCL White Clear ² LENSCLWH Clear White (Double Glaze Default) ² LENSWHWH White White ² LENSCLCL Clear Clear ² LENSWHWHWH White White White ³ LENSCLCLCL Clear Clear Clear ³ LENSCLWHCL Clear White Clear (Triple Glaze Default) ³ LENSWHCLWH White Clear White ³ LENSCLWHWH Clear White White ³ LENSWHCLCL White Clear Clear ³

Use **CUST** for Custom sized units.



Unit Type	Continous Venting	Skylight Frame Finish	Options	Curb Options
800MD Standard Frame	(blank) No venting	MI Mill (Default)	(blank) No Options	CELLCAP Cell Cap**
800SC So-Cal Skylight	1BL 1 Blade Continuous Vent	WH White	FMRTG Factory Mutual Approved	BUTYLTP Butyl Tape**
805SC Continuous Vent	2BL 2 Blade Continuous Vent	BZ Bronze	HVHZ High Velocity Hurricane Zone	
	3BL 3 Blade Continuous Vent	CF Custom	CE European Standard Certified	
	4BL 4 Blade Continuous Vent		LARR Los Angeles Approved	
	5BL 5 Blade Continuous Vent		ITBR Insulated thermal break	
	6BL 6 Blade Continuous Vent		NITBR No Insulated Thermal Break	
	7BL 7 Blade Continuous Vent		WSW Weather Sweep*	
	8BL 8 Blade Continuous Vent		NWSW No Weather Sweep	
	9BL 9 Blade Continuous Vent			
	10BL 10 Blade Continuous Vent			

Curb Type	Curb Thickness	Guard
NOCURB No Curb on the Order	WDC6 2x6 Wood Curb	(blank) With Guard (Default)
ARC39 9" Tall Fully Welded Insulated	WDC8 2x8 Wood Curb	BURGB Burglar Bar, 8" OC Grid with 1/2" Rod.
ARC312 12" Tall Fully Welded Insulated	WDC10 2x10 Wood Curb	NG No Guard
ARC314 14" Tall Fully Welded Insulated	WDC12 2x12 Wood Curb	<i>Safety Guard is 3/16 welded wire 6" x 6" pattern (4" x 4" in CA)</i>
ARC69 9" Steel Curb No Insulation	KDCURB14 14" Tall Knock-Down Curb	
ARC612 12" Steel Curb No Insulation	KDCURB12 12" Tall Knock-Down Curb	
ARC614 14" Steel Curb No Insulation	KDCURB9 9" Tall Knock-Down Curb	

*weather sweep available with Mill finish only ** required with AMBC1 Curbs *** diverter on W dimension 1) Single Glaze 2) Double Glaze 3) Triple Glaze

Note: When ordering these items: CELLCAP, BUTYLTP, 9", 12" or 14" Metal Roof Curb, please contact customer support (800) 289-4700.

